

815F Series 2

Soil Compactor



Engine

Engine Model	Cat® C9 ACERT™	
Gross Power	189 kW	253 hp
Net Power	173 kW	232 hp

Weights

Operating Weight	20 755 kg	45,765 lb
------------------	-----------	-----------

Shipping Specifications

Weight	20 345 kg	44,853 lb
--------	-----------	-----------

815F Series 2 Soil Compactor

The Cat® 815F Series 2 is specifically designed for heavy-duty compaction operations.

Power Train

- ✓ The Cat® C9 engine with ACERT™ Technology delivers maximum power and combines with Electronic Clutch Pressure Control and planetary powershift transmission to offer superior performance and reliability in heavy-duty compaction applications. **pg. 4**

Serviceability

- ✓ Many convenient service features such as hinged service doors, accessible scheduled maintenance points, conveniently located sight gauges, in-cab blade-type fuses and a separated cooling system make servicing easy. **pg. 12**

Structures

Advanced design, materials and robotic welding contribute to increased durability and overall machine strength. **pg. 6**

Complete Customer Support

Your Cat dealer is your one safe source for all your equipment needs. They offer a wide range of services that will fit your operation and keep you working longer with lower cost. **pg. 13**

Tamping Wheels and Tips

- ✓ Tamping wheels, with a modified chevron pattern for the tips, offer greater traction, penetration and compaction for high production. The new cast bases make cleaning the wheels easier when moving the 815F Series 2 to a new work site. **pg. 7**

The new 815F Series 2 Soil Compactor offers greater power, productivity and compaction. Combine this with the finest customer support system in the world – the Caterpillar® dealer network of service and parts – and you get the lowest operating cost with the best up-time in the industry!



Operator Station and Controls

Operator comfort and productivity are maximized by an excellent viewing area, careful positioning of levers, switches and gauges, attention to air quality and sound control, as well as built-in convenience for the operator's personal items. **pg. 8**

Blade

Designed for general production dozing, road grading, spreading and clean-up work. **pg. 10**

Optional Features

- ✓ Air suspension seat, air conditioning, No-SPIN rear differential, fast fill adapter and cleaner bars are available to enhance the 815F Series 2. A rear view monitor and satellite radio options help make the operator more efficient and comfortable. **pg. 11**



✓ *New Feature*

Power Train

The 815F Series 2 delivers top performance, durability and reliability.

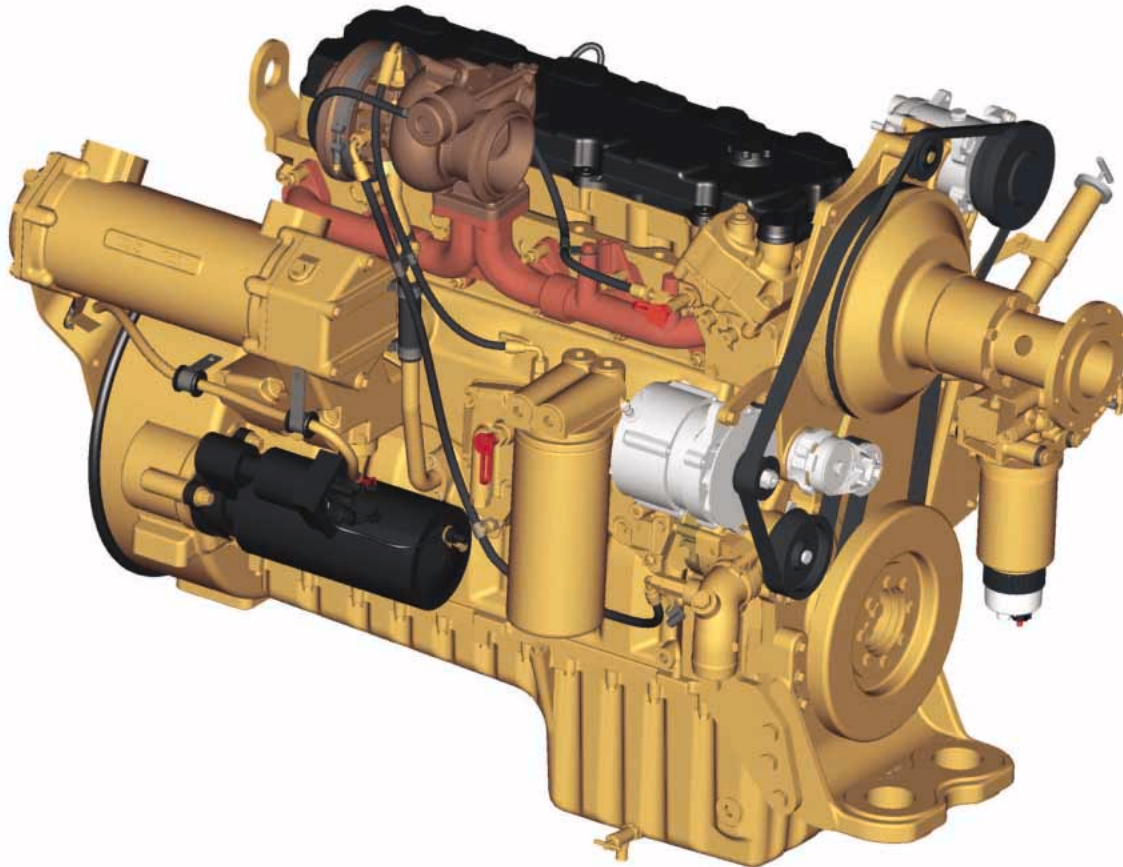

Cat® C9 ACERT Engine. Delivers, at a rated speed of 2,100 rpm, net power of 173 kW (232 hp) and meets the U.S. Environmental Protection Agency Tier 3 emissions regulations and Stage IIIA EU Emissions Directive 97/68/EC. With high horsepower and low displacement, this innovative engine provides excellent fuel economy and durability which can significantly reduce operating costs.

Torque Rise. Is increased as a result of the electronically controlled, computer-actuated unit injection fuel system that provides high injection pressure and more precisely controlled fuel delivery as the engine lugs back from rated speed.

ADEM™ IV Fuel System. Is a Caterpillar® electronic control module which provides improved engine response, performance, fuel efficiency, troubleshooting diagnostics and reduced emissions. It allows integration with the electronic transmission control for maximum power train efficiency.

Turbocharger. Packs more dense air into the cylinders for more complete combustion and lower emissions, improving performance and engine efficiency. These benefits are especially useful at high altitudes.

Air-to-Air Aftercooler. Reduces smoke and emissions by providing cooler inlet air for more efficient combustion. This also extends the life of the piston rings and bore.

Dual Cooling Jets. In the block spray oil on the piston skirt and cylinder bores keep ring temperatures low for long ring and liner life with excellent oil control.

Pistons. Are two piece articulated-type with forged steel crowns for excellent strength and aluminum skirts for reduced weight. The pistons are oil cooled for increased heat dissipation and longer life.

Valves. Four per cylinder allow for good air flow, enhancing fuel efficiency and heat rejection. Valves and unit injection system are camshaft-actuated for precise timing.

Crankshaft. Is steel-forged, carburized and induction-hardened for long-term durability. It is dynamically balanced for smooth operation. The crankshaft is completely regrindable, and the connecting rods can be removed through the tops of the cylinders for easy servicing.

Cat Engine Oil. Is formulated to optimize engine life and performance and is strongly recommended for use in Cat diesel engines. Engine oil change interval is 500 hours.

Cat Remanufactured Parts. Are available, along with dealer proposed repair options, which increase machine availability and reduce total repair costs.

Cat Planetary Powershift Transmission. Features heavy-duty components to handle tough jobs. The 345.4 mm (13.6 in) planet drives operate in all gears, forward and reverse. The addition of Electronic Clutch Pressure Control (ECPC) contributes to improved shift quality, reduced torque spikes and overall transmission durability.

Heavy-Duty Axles and Brakes. Are designed to last in all kinds of operating conditions. Two front axle disc brakes provide improved braking capability and better heat dissipation. Planetary final drives use free-floating, bronze sleeve bearings in the planet gears.

- Oil disc brakes are adjustment-free and fully enclosed to lock out contaminants.

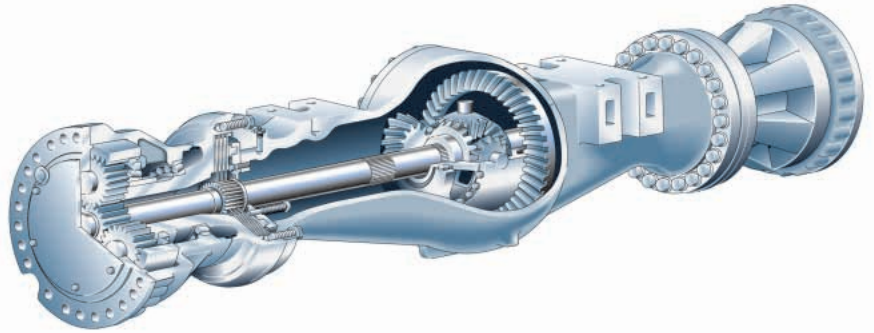

Front Axle. Is rigidly mounted to the frame to support the weight of the compactor, internal torque loads and external loads applied during compacting and dozing operations.

Rear Axle. Includes a trunnion, two trunnion supports and associated bearings, allowing it to oscillate plus or minus 12 degrees.

Four Piece Axle. Contains two axle shaft housings – the center housing and the intermediate housing. Features and benefits of this design include:

- Inboard brakes on the front axle only are positioned immediately adjacent to the differential and operate on the low torque side of the final drive, requiring less braking to stop the machine.

Structures

Enhanced design and materials provide superior strength to the purpose built structures of the 815F Series 2.

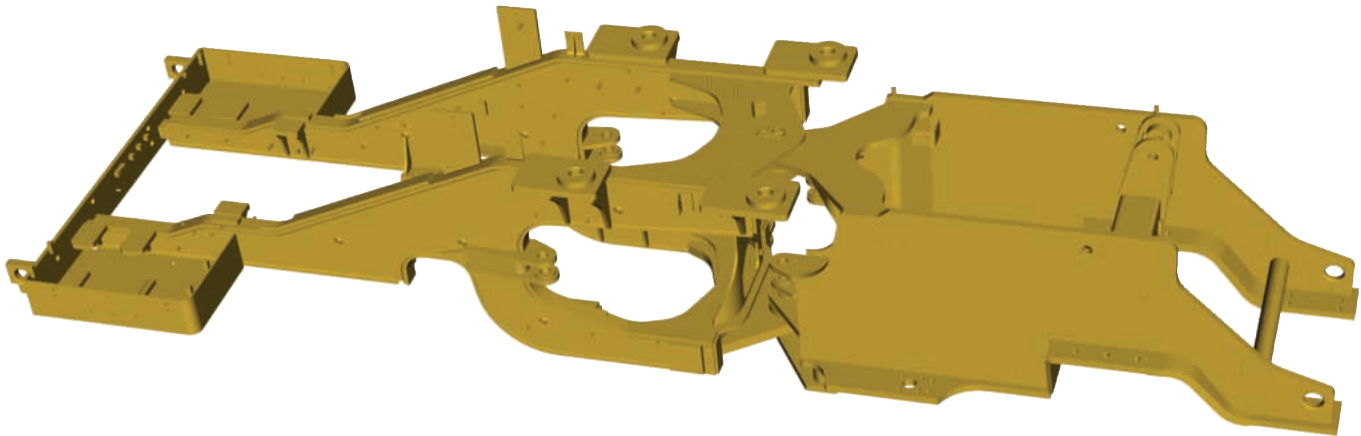

Structure Construction. Combines the use of robotic welding on up to 90 percent of the 815F Series 2 with castings in several areas to increase strength by helping spread the loads and reduce the number of parts. This provides highly consistent welds with deep plate penetration and excellent plate fusion. The benefits are increased durability and fatigue strength. The computer controlled machining ensures the alignment of pin bore, axle pad, cab mount and transmission/engine components.

Box Section Engine Frame. Designed to resist twisting and torsional forces, the box section engine end frame provides a solid foundation for the axles, engine and transmission.

Front Frame. With two plates provides maximum structural strength during compaction and dozing applications.

Spread Hitch Design. Improves load distribution by reducing loads to the hitch bearings. The large center hitch design improves hydraulic line routing and makes service access easier.

Upper and Lower Hitch Pins.

Pivot on double-tapered roller bearings. Box-style sections in the hitch pins and crossmember assembly improve frame structure strength. Increased diameter lower hitch pins add to the robust design.

Engine and Transmission Mounts.

With rubber isolation mount design reduces noise and vibration.

Tamping Wheels and Tips

The heart of any compaction system.

Wheel Design. Gives the operator four-wheel width coverage in just two passes with front and rear wheel tracking that eliminates gaps and overlaps.

Chevron Tamping Wheel Tip Design.

Is used for equal compaction in forward or reverse. Tips are full perimeter and are replaceable. The tip is welded to a base assembly, which is then welded directly to the drum. There are 12 tips per row and 60 tips per wheel for excellent compaction.

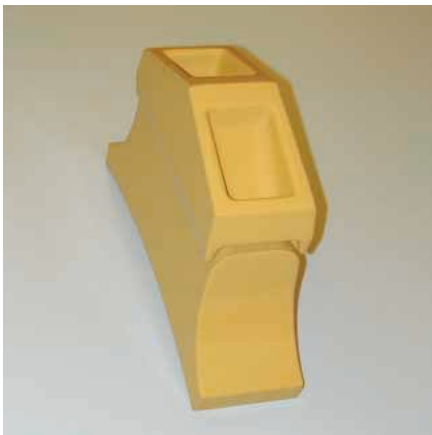

Symmetrical Tamping Wheel Tip Pattern. Has a modified chevron tamping wheel tip design to provide greater ground pressure, more compaction, a smooth ride and excellent traction. Tip height is 190 mm (7.5 in) and width is 168 mm (6.6 in).



Cleaner Bars. Help keep the drums free of carry-over dirt regardless of rolling direction. A pass-through bolt design allows for easier serviceability.

Adjustable Cleaner Bar Tip.

Are constructed from cutting edge steel that is heat treated and direct hardened, which increases the wear life and translates into lower operating costs.

Compaction. Is achieved from the bottom of the lift to the top. The tapered pads walk out of the lift without “fluffing” the soil. The top of the lift is compacted and the surface is relatively smooth and sealed so hauling units are able to maintain a high speed when traveling over the fill. 815F Series 2 travel speed allows for four forces of compaction: pressure, manipulation, impact and vibration. Since it can also spread fill, the number of spreader tractors may be able to be reduced.

Operator Station and Controls

Comfort and control...with a top quality operator's station productivity is maximized.



1 Exceptional All-Around Viewing Area.

Reduces strain and fatigue, making operators more productive.

2 Caterpillar® Monitoring System.

With electronic analog gauges is a highly effective and reliable warning and diagnostic system.

As a warning system, it constantly checks machine functions and tells the operator when there is a problem. Easy-to-read gauges display fuel level, temperatures for engine coolant, transmission and hydraulic oil, engine rpm and gear range. Hour meter, odometer and analog tachometer readings are also displayed.

As a diagnostic system, it identifies conditions, shows current readings and plays back maximum or highest readings registered during recent operations.

The right side panel contains a three level warning system, providing full-time monitoring of key functions. The system alerts the operator of immediate or impending problems with air inlet temperature, brake oil pressure, electrical system, low voltage, engine oil pressure, engine over-speed, fuel filter status, parking brake status, steering oil pressure and transmission filter status.

3 Quick Gear Kick Up/Down Button.

Allows the operator easily downshift or upshift to a different gear. It is a convenient way to shift that saves time and effort.

4 Ignition Key Start/Stop Switch.

Is positioned for easy machine starting and stopping.

5 12-Volt Power Supply and Electronic Technician (Cat ET) Diagnostics.

Is provided inside the cab for powering radios, telephones or a laptop computer. This is particularly useful for powering a laptop running Cat ET to access the enhanced engine and transmission control system diagnostics.

6 Steering Column. Adjusts to multiple positions. The leather-like steering wheel and transmission control provide a sure grip and comfortable feel. The horn is conveniently located in the center of the steering wheel.

7 Pilot-Operated Blade Controls.

Are conveniently located and allow for precise blade movement.

8 Operator Seat. Is designed for comfort and support. Seat cushions reduce pressure on the lower back and thighs while allowing unrestricted arm and leg movement.

- A fully adjustable air suspension seat with self-contained compressor is available as an option.

9 Built-In Storage Space. Is designed to hold cups, lunch box, insulated bottle and personal items.

10 Repositioned Vents. Throughout the cab keep fresh air flowing while improving the cab's heating, cooling, defrost and defog capability.

11 Throttle Lock. Allows an operator to set the engine speed and remove his foot from the governor (accelerator) pedal much like cruise control on an automobile. Using this feature increases productivity, fuel efficiency and improves operator comfort.

12 Decelerator Pedal. On the left acts as both an engine decelerator and a brake that overrides the engine speed selected by the throttle lock. This enables the operator to slow down when throttle lock is engaged and to return to throttle lock without pressing a button. It aids in maneuvering around scrapers, haul trucks, tractors or any other obstacle.

13 Windshield Washers/Wipers.

With in-the-blade washer delivery system are standard features on front and rear windows. The front wiper has intermittent speed capability.

14 Rear Vision Camera Monitor.

Connected to a camera mounted on the radiator guard, this monitor allows the operator to see the area behind the machine.

Blade

Multiple box-section construction with heat-treated moldboard and DH-2 steel cutting edges and end bits contribute to long blade life.



Blade Package. Consists of the blade, push-arms, trunnion mounting, dozer-length skid plate with replaceable wear plates, reversible cutting edges, self-sharpening end bits, hydraulic lines guard and hydraulic lift cylinders.

Operator Controls. The tilt cylinder is an option that gives the 815F Series 2 more versatility when dozing. The controls are seat-mounted and located in a convenient location to the right of the operator.



Outside Mounted Straight Blade.

With multiple box section construction includes a heat treated moldboard and DH-2™ steel cutting edges and end bits for long life. The outside mounting is a stronger design because stresses are put on the frame rather than the blade so blade flexing is reduced. It also allows for higher lift and a wider blade can be used than with an inside mounted design.



Applications. The 815F Series 2 excels at compacting, spreading fill, backfilling and boosting scrapers. With the ability to work at higher speeds over other types of soil compactors, the 815F Series 2 can keep up with a fast-moving scraper fleet or an articulated truck hauling operation. When speed and dozing capability are required job duties for a soil compactor, the 815F Series 2 has no equal.

Optional Features

Available options augment the 815F Series 2 to meet your needs.

Rear Vision Camera. Uses a camera mounted on the radiator guard and a monitor in the cab to allow the operator to see the area directly behind the machine.



Air Suspension Seat. Provides added comfort for the operator so productivity stays high.

Air Conditioner. Uses blended air and R134a refrigerant for immediate temperature changes.

Radios. Several radio options are available factory installed: AM/FM CD or AM/FM CD with satellite radio (a service contract is required from a satellite radio provider).



Product Link. Allows the customer and/or dealer to monitor the machine from a remote location.

Rear No-SPIN Differential. Replaces the rear standard differential. It delivers maximum traction in low traction or inconsistent ground conditions.

Fast Fill Adapter. Used during peak periods when high production is needed and little down time can be afforded for fueling. Fuel is pumped into the tank through a filling nozzle at rates up to 378.5 liters (100 gallons) per minute. As fuel enters the tank, air is forced out through an open vent. When the tank is full, the vent closes and the filling nozzle automatically shuts off.

High Speed Oil Change. Uses an evacuation system to speed up the engine oil change which helps to reduce the service time.

Turbine Pre-Cleaner Group. Replaces the standard stratatube air cleaner with a turbine-style air intake cleaner which is useful in dry, dusty work conditions.

Heavy Duty Cleaner Bar Tips. The shape of these tips enables them to penetrate the wheel more efficiently than the standard cleaner bar tips, thereby reducing wheel drag and improving machine performance. Constructed from cutting edge steel used for blades and buckets, this high alloy steel is heat treated and direct hardened, which increases tip wear life by up to 240 percent over other designs in sticky, abrasive soil applications.

High Intensity Discharge (HID) Lights. Adds four lights on the cab and two on the radiator guard to brighten up the work area. HID lights are two times brighter than the standard halogen lights.

Note: These lights will be available mid-2007.

Serviceability

If maintenance is simple and accessible, it gets done and that's how it is on the 815F Series 2.



Engine Access. All metal engine enclosure and hinged access doors allow for easy daily maintenance and inspection.

Left Side Service Access. Provides convenient entry to the engine oil filter, grease points (lower), air filter (front), power train oil dipstick (top), coolant sight gauge (top), power train oil fill (below cab), power train oil filter and high speed engine oil fill.



Right Side Service Access. Puts the the fuel filter and water separator, fuel primer and engine oil dipstick within easy reach.

500 Hour Oil Change Interval.

Increases uptime and production by doubling the time between oil and filter changes without requiring increased oil sump capacity.



Hinged Hydraulic Oil Cooler. Can be swung open without special tools.

Hinged Air Conditioning Condenser. Swings open and coupled with the swing out oil cooler allows the cooling system to be cleaned quickly and easily.

Operator Station. Can be removed or replaced in about 45 minutes without having to disconnect hydraulic lines. Quick disconnect couplings allow fast disconnect of the air conditioning unit without releasing refrigerant.

Engine Shutdown Switch. Is located inside the left engine enclosure panel for simple access and extended switch life.

Battery Box. Is located in the right side bumper for convenient access to the maintenance-free batteries.

Tool Box. Is located in the left side bumper for additional protection against harsh work environments.

In-Cab Blade-Style Fuses. Are new to the 815F Series 2 to improve fuse serviceability and reliability.

Complete Customer Support

Caterpillar® dealers are the equipment experts to help you with all your equipment needs.

Machine Selection. Make detailed comparisons of the machines under consideration before purchase. Cat dealers can estimate component life, preventative maintenance cost and the true cost of lost production.

Purchase. Look past initial price. Consider the financing options available as well as day-to-day operating costs. Look at dealer services that can be included in the cost of the machine to yield lower equipment owning and operating costs over the long run.

Customer Support Agreements. Cat dealers offer a variety of product support agreements and work with customers to develop a plan that best meets specific needs. These plans can cover the entire machine, including attachments, to help protect the customer's investment.

Product Support. You will find nearly all parts at our dealer parts counter. Cat dealers use a worldwide computer network to find in-stock parts to minimize downtime.

You can save money with genuine Cat Reman parts and receive the same warranty and reliability as new products at cost savings of 40 to 70 percent.

Operation. Improving operating techniques can boost your profits. Your Cat dealer has training video tapes, literature, application and equipment training courses, along with many other ideas to help you increase productivity.



Maintenance Services. More equipment buyers are planning for effective maintenance before buying equipment. Choose from your dealer's wide range of maintenance services at the time you purchase your machine. Repair option programs guarantee the cost of repairs up front. Diagnostic programs such as S·O·SSM and Coolant Sampling and Technical Analysis help you avoid unscheduled repairs.

Replacement. Repair, rebuild or replace? Your Cat dealer can help you evaluate the cost involved so you can make the right choice.

Engine

Engine Model	Cat® C9 ACERT™	
Gross Power	189 kW	253 hp
Net Power	173 kW	232 hp
ISO 3046-2	173 kW	232 hp
ISO 9249	175 kW	235 hp
SAE J1349	173 kW	232 hp
EEC 80/1269	175 kW	235 hp
Torque Rise	30%	
Bore	112 mm	4.4 in
Stroke	149 mm	5.9 in
Displacement	8.8 L	537 in ³
Cylinders	6	

- Engine meets U.S. Environmental Protection Agency Tier 3 emissions regulations and Stage IIIA EU Directive/97/68/EC.
- Engine power ratings apply at 2,100 rpm when tested under the specific standard conditions for the specified standard.
- Power rating conditions based on standard air conditions of 25° C (77° F) and 100 kPa (29.8 Hg) dry barometer, using 25° API gravity fuel having an LHV of 42 780 kJ/kg (18,390 Btu/lb) when used at 29° C (85° F) [reference a fuel density of 828.9 g/L (7.001 lb/gal)].
- Torque rise at 1,200 rpm.

Transmission

Forward 1	6.2 km/h	3.9 mph
Forward 2	10.7 km/h	6.7 mph
Forward 3	17.6 km/h	11 mph
Reverse 1	7 km/h	4.4 mph
Reverse 2	12.1 km/h	7.6 mph
Reverse 3	19.5 km/h	12.2 mph

Steering

Steering Angle	±42°
----------------	------

Wheels

Drum Width	991 mm	3 ft 3 in
Drum Diameter	1029 mm	3 ft 5 in
Outside Diameter	1425 mm	4 ft 9 in
Tips per Wheel	60	
Tips per Row	12	

Hydraulic System

Relief Valve Setting	15 550 kPa	2,255 psi
Lift Cylinder Bore × Stroke	101.6 mm × 627 mm 3.99 in × 24.68 in	
Tilt Cylinder Bore × Stroke (option)	101.6 mm × 167 mm 3.99 in × 6.6 in	

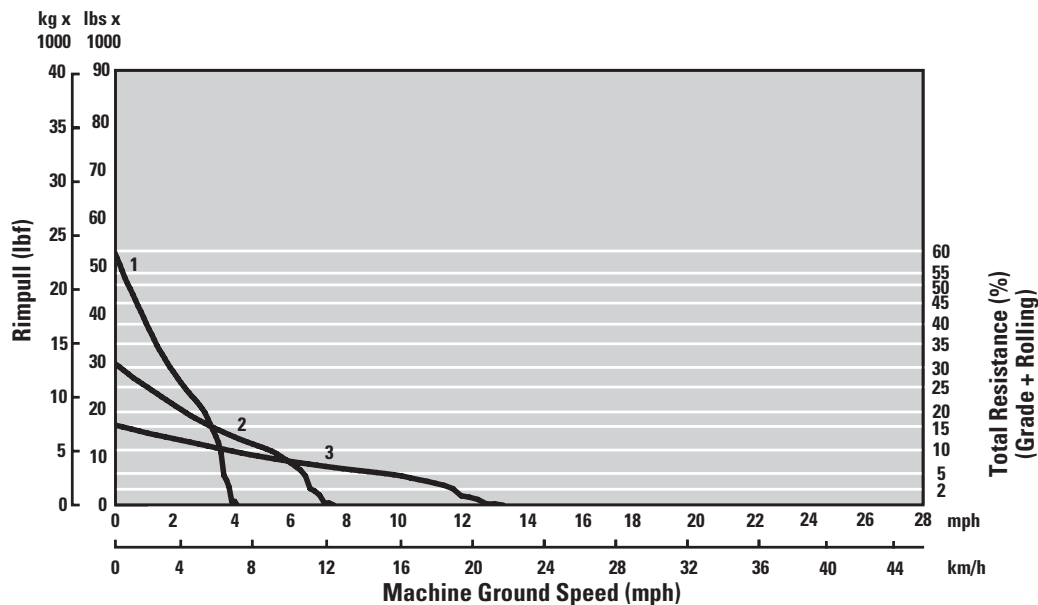

Axles

Front	Fixed
Rear	Oscillating $\pm 12^\circ$

Brakes

Standards	Meet OSHA regulations
-----------	-----------------------

Cab

ROPS/FOPS	Meet SAE and ISO standards
-----------	----------------------------

- Cat cab and Rollover Protective Structure/Falling Object Protective Structure (ROPS/FOPS) are standard in North America, Europe and Japan.
- ROPS meets SAE J394, SAE 1040 APR88 and ISO 3471-1986 standards.
- FOPS meets SAE J231 JAN81 and ISO 3449-194 standards.

Sound Performance

Standards	Meet required sound standards
-----------	-------------------------------

- The operator exposure Leq (equivalent sound pressure level) measured according to the work cycle procedures specified in ANSI/SAE J1166 OCT98 is 78 dB(A), for the cab offered by Caterpillar, when properly installed, maintained and tested with the doors and windows closed.
- Hearing protection may be needed when operating with an open operator station and cab (when not properly maintained or doors/windows open) for extended periods or in noisy environment.
- The exterior sound pressure level for the standard machine measured at a distance of 15 m (49.2 ft) according to the test procedures specified in SAE J88 JUN86 mid-gear-moving operation is 80 dB(A).
- The sound power level is 111 dB(A) measured according to the dynamic test procedure and conditions specified in ISO 6395:1988/Amd. 1:1996 for a standard machine configuration.

Blades

Moldboard Length	3652 mm	11 ft 12 in
Height, Including Cutting Edge	860 mm	2 ft 10 in
Maximum Depth of Cut	215 mm	9 in
Maximum Lift Above Ground	814 mm	2 ft 9 in
Blade Tip Angle – Total	59.2°	
Blade Tilt Angle – Right – Mechanical	6.5°	
Blade Tilt Angle – Left – Mechanical	5.4°	
Width Over End Bits	3761 mm	12 ft 4 in

Weights

Operating Weight	20 755 kg	45,765 lb
------------------	-----------	-----------

Service Refill Capacities

Fuel Tank	446 L	117.8 gal
Cooling System	55 L	14.5 gal
Crankcase	34 L	9 gal
Transmission	50 L	13.2 gal
Differentials and Final Drives – Front	65 L	17.1 gal
Differentials and Final Drives – Rear	65 L	17.1 gal
Hydraulic Tank	88 L	23.2 gal

Dimensions

Height to Bottom of Ladder	463 mm	1 ft 7 in
Width Over End Bits	3791 mm	12 ft 5 in
Width Over Drums	3243 mm	10 ft 8 in

Operating Specifications

Turning Radius Blade – Outside	6452 mm	21 ft 3 in
Turning Radius Blade – Inside	2967 mm	9 ft 9 in

Shipping Specifications

Weight	20 345 kg	44,853 lb
Height	3347 mm	11 ft
Width	3652 mm	11 ft 12 in
Depth	6845 mm	22 ft 6 in

Dimensions

All dimensions are approximate.

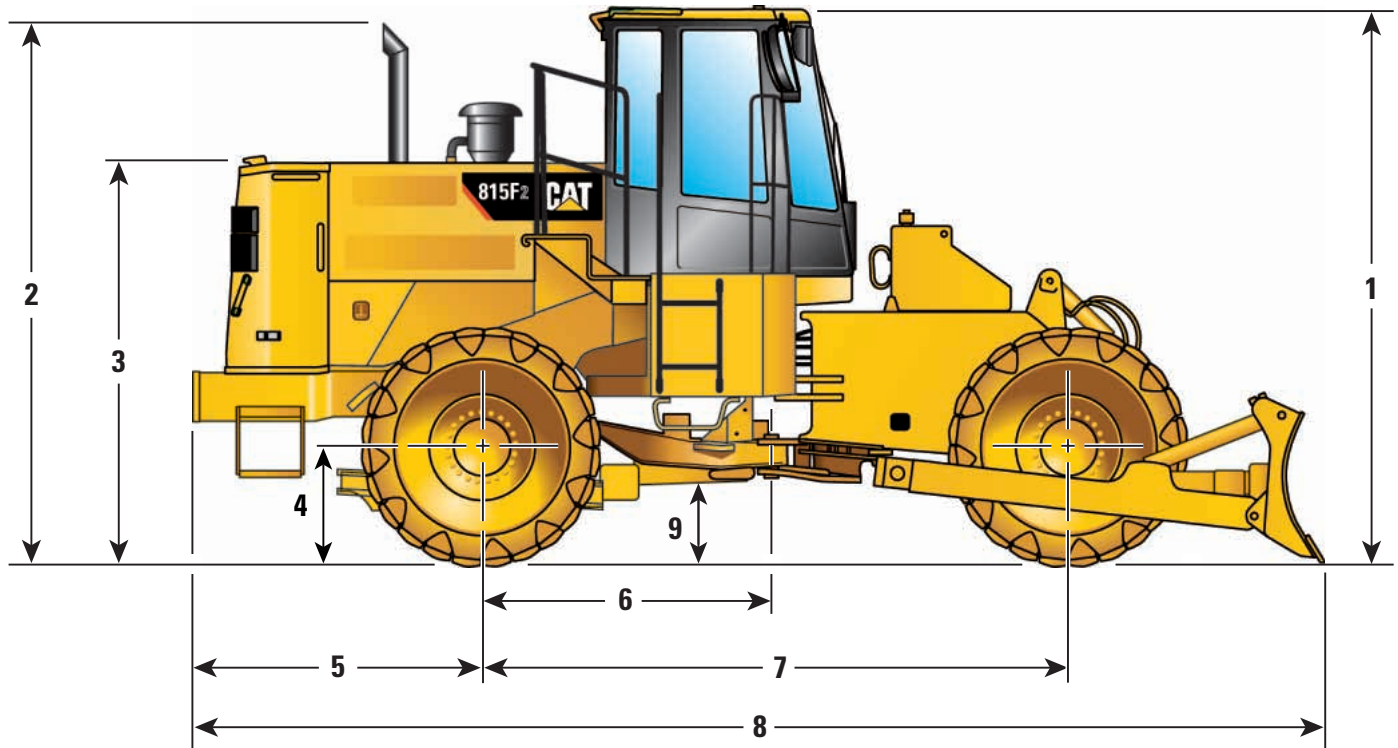

1	Height to Top of Cab	3347 mm	10 ft 12 in
2	Height to Top of Exhaust Pipe	3225 mm	10 ft 7 in
3	Height to Top of Hood	2395 mm	7 ft 11 in
4	Height to Rear Bumper	770 mm	2 ft 7 in
5	Center Line of Rear Axle to Edge of Rear Bumper	1871 mm	6 ft 2 in

6	Center Line of Rear Axle to Hitch	1675 mm	5 ft 6 in
7	Wheelbase	3350 mm	10 ft 12 in
8	Length with Blade on Ground	6845 mm	22 ft 6 in
9	Ground Clearance	390 mm	1 ft 4 in

Standard Equipment

Standard equipment may vary. Consult your Caterpillar dealer for details.

ELECTRICAL

- Alarm, backup
- Alternator (80 amp)
- Batteries, maintenance-free (2)
- Diagnostic connectors
- Lighting system, halogen (front, rear and cab-mounted)
- Starting and charging system (24-volt)
- Starting receptacle for emergency starts

OPERATOR ENVIRONMENT

- Blade control system locks
- Cab, pressurized and sound suppressed (ROPS/FOPS)
includes antenna, speakers and converter (12-volt,
10-15 amp)
- Coat hook
- Cigar lighter and ashtray
- Caterpillar Monitoring System
 - Instrumentation, Gauges
 - Engine coolant temperature
 - Fuel level
 - Hydraulic oil temperature
 - Speedometer/Tachometer
 - Transmission oil temperature
 - Instrumentation, Warning Indicators
 - Air inlet temperature
 - Brake oil pressure
 - Electrical system, low voltage
 - Engine oil pressure
 - Engine over-speed
 - Fuel filter status
 - Parking brake status
 - Steering oil pressure
 - Transmission filter status

- Dome light (cab)
- Fuses, blade style (in-cab)
- Heater and defroster
- Horn, electric (steering wheel mounted)
- Hydraulic steering
- Lunchbox and beverage holders
- Mirrors, rearview (interior mounted)
- Seat, mechanical suspension
- Seat belt, retractable, 76 mm (3 in) wide
- Steering column, adjustable
- Wet-arm wipers/washers (front and rear)
 - Intermittent front wiper

POWER TRAIN

- Brakes, fully hydraulic, enclosed, wet-disc
- Engine, Cat® C9 ACERT™
- Fuel priming pump
- Muffler
- Radiator, Next Generation Modular (NGMR)
- Starting aid (ether)
- Torque converter
- Transmission, planetary (3 forward/3 reverse speeds)
 - Electronic Clutch Pressure Control

OTHER STANDARD EQUIPMENT

- Cat O-ring face seals/couplings
- XT™ hoses
- Cleaner bars
- Guards
 - Crankcase
 - Power train
 - Parking brake
 - Radiator
 - Drive shaft
- Hood, metallic with lockable service doors
- Hitch, drawbar with pin
- Hydraulic oil cooler
- Oil sampling valves
- Trunnion
- Tamper wheels
- Vandalism protection caplocks

BULLDOZERS

- Bulldozer blade, hydraulics and linkage are not included
in standard equipment

ANTIFREEZE

- Premixed 50 percent concentration of Extended Life
Coolant with freeze protection to -34° C (-29° F)

Optional Equipment

(with approximate change in operating weight)

Optional equipment may vary. Consult your Caterpillar dealer for specifics.

	kg	lb
Air conditioner	36	80
Air suspension seat	32	71
Attachment cleaner bar/tips	141	311
Bulldozer arrangement includes blade, hydraulic cylinder, push arms, mounting gp and lines	1393	3,072
Canopy, ROPS	-176	-389
Differential, No-SPIN rear	1.8	4
Extended Life Coolant -50° C (-58° F)	0	0
External mirrors	28	62
Fast fuel adapter	2.7	6
Heater, engine coolant	1.8	4

	kg	lb
HID lights	9.8	21.6
High speed oil change	3.4	7.5
Hydraulic tilt cylinder	111	245
Internal (panoramic) mirror	1.9	11
Pre-cleaner group – turbine	7	15.4
Product Link	4.4	9.7
Radios		
Radio CD AM/FM	1.6	3.5
Radio CD AM/FM (SIRIUS Satellite)	5.8	12.8
Radio CD AM/FM (XM Satellite)	5.8	12.8
Rear vision camera	7.9	17.4
Visor, cab	2.3	5

Notes

815F Series 2 Soil Compactor

For more complete information on Cat products, dealer services,
and industry solutions, visit us on the web at www.cat.com

© 2006 Caterpillar
All Rights Reserved
Printed in U.S.A.

Materials and specifications are subject to change without notice.
Featured machines in photos may include additional equipment.
See your Caterpillar dealer for available options.

AEHQ5727 (10-06)

Replaces AEHQ5486-02

CAT, CATERPILLAR, ACERT, their respective logos, "Caterpillar Yellow," and the
POWER EDGE™ trade dress, as well as corporate and product identity used herein,
are trademarks of Caterpillar and may not be used without permission.

CATERPILLAR®